



Model 6A01-11—Surface-Mounted Foam Tank Type Vertical **Bradex**<sup>®</sup>

Diplomat Series

**Product Materials**

**BODY:** Heavy gauge stainless steel with exposed surfaces in architectural satin finish. Front has matching curvature to other Bradley Diplomat washroom accessories.

**WALL PLATE:** ABS plastic.

**RESERVOIR:** reusable, cap-sealed plastic tank, holds 27 oz.

**BATTERY BOX:** Plastic, holds (4), "AA" Alkaline batteries, not included.

**Capacity**

27 oz.(800 ml) of bulk foam soap and foam sanitizer

**Operation**

Place hands under spout and hold to dispense foaming liquid. (2"-3" sensing range.) Sight gauge indicates refill time. Refill by unlocking lock with special key (supplied), swinging open dispenser body. Remove cap to refill internal tank.

**Installation**

Verify all rough-in dimensions prior to installation. Secure separate mounting bracket with mounting screws (included) at holes provided. Unlock the cover. Open and remove tank. Secure unit to wall by installing the mounting screws. Install batteries (not included). Fill tank with premixed, bulk foam soap/sanitizer. Close and lock the cover.

**Guide Specification**

Soap/Sanitizer Dispenser: Bradley Corp. Diplomat Series Model 6A01: Surface-mounted automatic foam soap/sanitizer dispenser, with face formed with contemporary contours, radii, and finish matching related accessories in manufacturer's designer series. Capacity 27 oz (800 ml). Equipped with hinged cover and completely concealed mounting plate. Vandal resistant filler hole cover and sight gauge. Corrosion-resistant foam soap/sanitizer valve.

**Overall dimensions: 4<sup>5</sup>/<sub>8</sub>"W x 10<sup>9</sup>/<sub>16</sub>"H x 4<sup>3</sup>/<sub>16</sub>"D.**

**MasterFormat Title:** Commercial Toilet Accessories

**MasterFormat Number:** 10 28 13.13

**OmniClass Title:** Soap Holders, Dispensers

**OmniClass Code:** 23.40.20.21.34

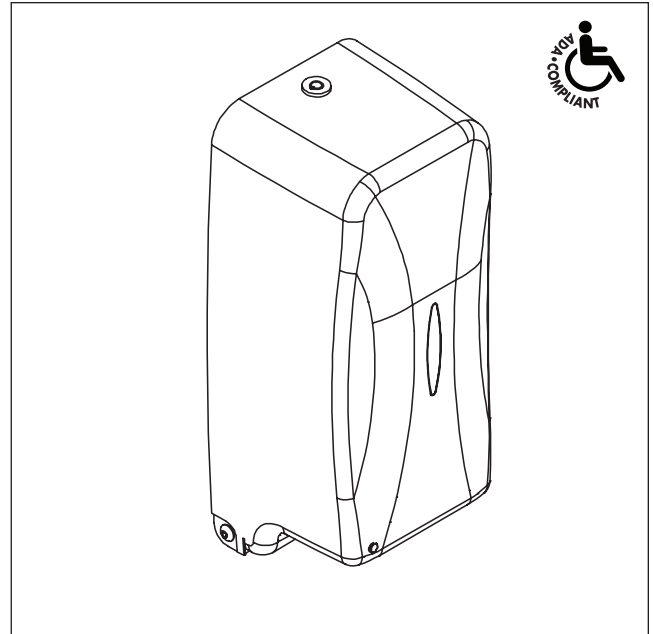

**For information on Warranties, Maintenance and BAA/ARRA Compliance, visit our web site at: [bradleycorp.com/products/accessories/](http://bradleycorp.com/products/accessories/).**

**ADA Compliant**

- Consult local and national accessibility codes for proper installation guidelines.
- Conformity and compliance to local and national codes is the responsibility of the installer.

Orders composed of products indicated as **Bradex**<sup>®</sup> will be available to ship in three days after receipt of order at the factory. There is no pricing penalty for this service from Bradley.



Dimensions

(mm)

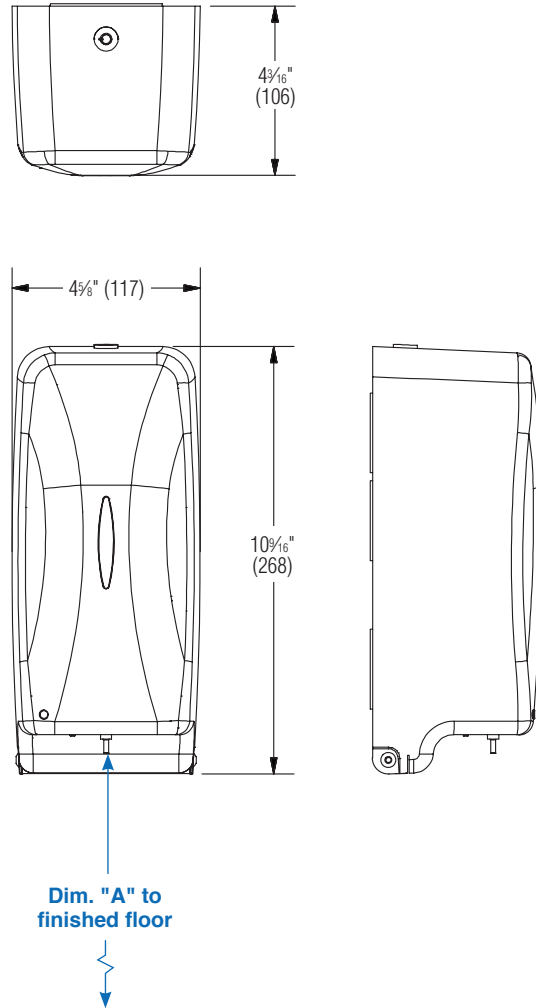

Dim. "A" Key Surface:	For Dim. "A"	Locate Top of Unit	Locate Bottom of Unit
Bottom of dispensing tube to finished floor	48" (1219)	58" (1473)	47 1/16" (1205)
	45" (1143)	55" (1397)	44 1/16" (1129)
	42" (1067)	52" (1321)	41 1/16" (1053)
	40" (1016)	50" (1270)	39 1/16" (1002)

Orders composed of products indicated as **Bradex**® will be available to ship in three days after receipt of order at the factory. There is no pricing penalty for this service from Bradley.